

Spare parts list
Liste de pièces de rechange
Ersatzteilliste
Lista de piezas de repuesto
Lista de peças
Listino ricambi
Onderdelenlijst
Καταλογος ανταλλακτικῶν
Varaosu luettelo
Reservdelsliste
Reservdelfortegnelse
Reservdelsförteckning

Motor breaker
Marteaux-piqueurs autonome
Motorhammer
Rompedor autónomo
Martelo demolidor
Demolitore a motore
Autonome sloophamer
Κρουστική σκῦρα
Moottorikanki
Motorafbryder
Maiselmaskin
Motorspett

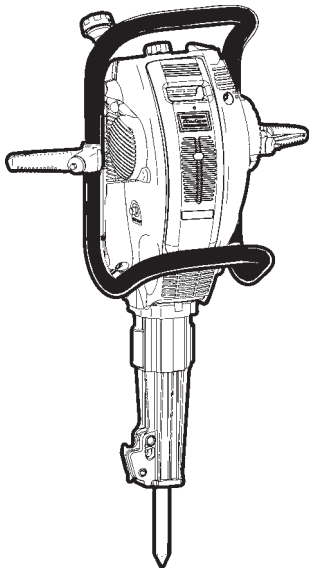

COBRA TT
COBRA TT/AWD

A

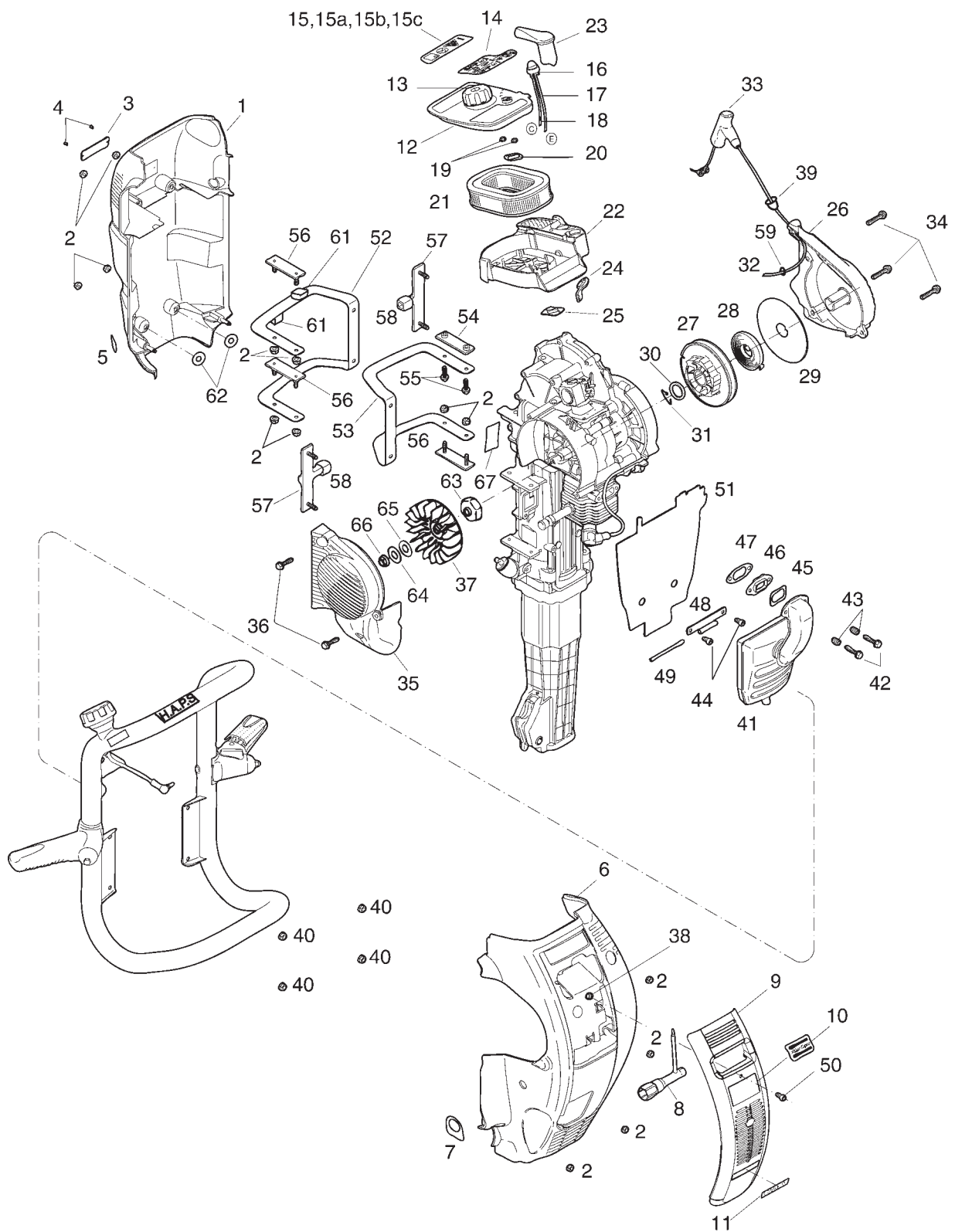

Fig. No. No. de fig. Abb. Nr. Núm de fig. Fig. No No rif. Fig. Nr Αριθ Σχ. Kuva nr. Fig. nr. Fig. nr. Fig. nr.	Ordering No Référéce Bestellnummer Núm. pedido Encomenda No No Cat. Bestel nr. Αριθ. Παραγγελίας Tilaus nro. Bestillingsnummer Bestillingsnummer Best. nummer	Quantity Quantité Anzahl Cantidad Qvantidade Quantità Aantal Ποσότητα Lukumäärä Antal Antall Antal	Description Description Beschreibung Descripción Descriçao Descrição Omschrijving Περιγραφή Nimitys Beskrivelse Beskrivelse Beskrivning	Contents Sommaire Inhalt Indice Conteúdo Contenuto Inhoud Περιεχόμενα Sisältö Inndhold Innhold Innehåll	Dimensions Dimensions Abmessungen Dimensiones Dimensões Dimensioni Afmetingen Διαστάσεις Mitat Dimensioner Dimensjoner Dimensioner
1	9234 0000 20	1	Back Cover		
2	9232 0207 50	14	Nut		M6
[3]	9232 2237 91	1	CE Machine Data Plate	3-4	
3	-	1	CE Machine Data Plate	*)	
4	-	2	Rivets	*)	
5	9234 0003 54	1	Oil Level Decal		
[6]	9234 0000 19	1	Front Cover	6, 38	
6	-	1	Front Cover	*)	
7	9234 0003 45	1	Decal, De-Compression, Valve		
8	9234 0000 56	1	Spark Plug Key		
[9]	9234 0006 19	1	Service Cover Assy	9 -11, 38, 50	
9	-	1	Service Cover	*)	
10	9234 0009 95	1	Decal, Atlas Copco		
11	9234 0009 97	1	Decal, TT		
[12]	9234 0010 08	1	Filter Cover Assy	12-14, [15]	
12	-	1	Filter Cover	*)	
13	-	1	Filter Cover Knob	*)	
14	9234 0003 43	1	Decal, start instruction		
[15]	9234 0010 09	1	Decal, set	15, 15a, 15b, 15c	
15	-	1	Decal, sound/shank/warnings triangle	32X160 / 1 1/4"X6 1/4" *)	
15a	-	1	Decal, sound/shank/warnings triangle	28X160 / 1 1/8"X6 1/4" *)	
15b	-	1	Decal, sound/shank/warnings triangle	32X152 / 1 1/4"X6" *)	
15c	-	1	Decal, sound/shank/warnings triangle	28X152 / 1 1/8"X6" *)	
[16]	9234 0001 24	1	Prime Pump Assy	16-18	
16	-	1	Prime Pump	*)	
17	9234 0002 97	1	Pipe, tank connection (E)		L=340
18	9234 0002 98	1	Pipe, carburettor connection (C)		L=169
19	9232 0208 80	2	Nut		M5
20	9234 0000 63	1	Plate		
21	9234 0001 36	1	Air Filter		
[22]	9234 0002 65	1	Filter Housing Assy	[16] 19, 20, 22-25	
22	-	1	Filter Housing	*)	
23	9234 0000 26	1	Choke Handle		
24	9234 0010 30	1	Choke Arm		
25	9234 0001 37	1	Gasket		
[26]	9234 0001 14	1	Starter Cover Assy	[26] [27] 33, 39, 59	
[26]	9234 0006 86	1	Starter Cover	34	
[27]	9234 0001 15	1	Pulley Wheel Assy	27-32	
27	-	1	Pulley Wheel	*)	
28	9234 0004 91	1	Starter Spring		
29	9234 0000 40	1	Fiber Washer, inner		
30	9234 0000 41	1	Washer		
31	9234 0000 54	1	Locking Spring		

A

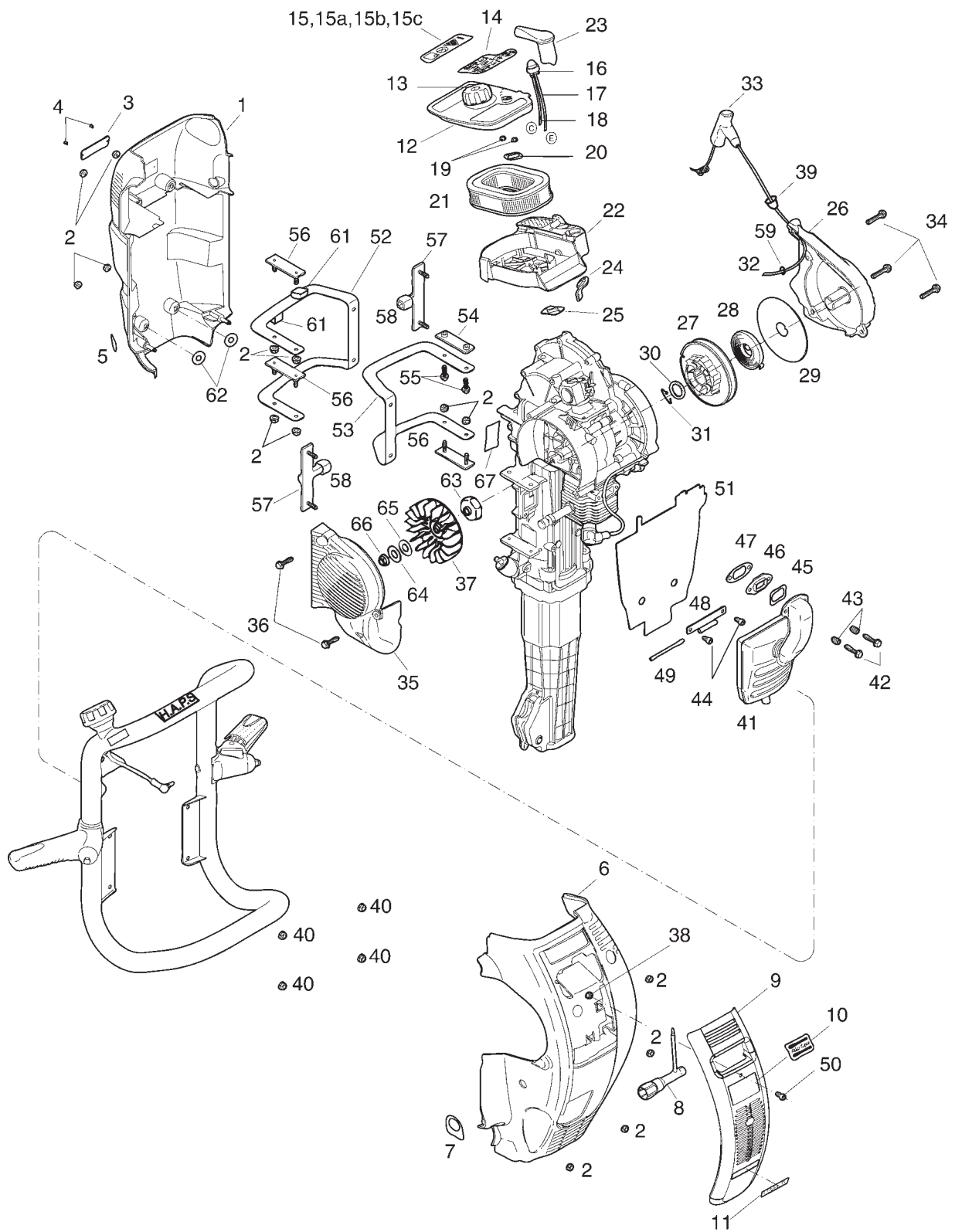

Fig. No. No. de fig. Abb. Nr. Núm de fig. Fig. No No rif. Fig. Nr Αριθ Σχ. Kuva nr. Fig. nr. Fig. nr. Fig. nr.	Ordering No Référéce Bestellnummer Núm. pedido Encomenda No No Cat. Bestel nr. Αριθ. Παραγγελίας Tilaus nro. Bestillingsnummer Bestillingsnummer Best. nummer	Quantity Quantité Anzahl Cantidad Qvantidade Quantità Aantal Ποσότητα Lukumäärä Antal Antall Antal	Description Description Beschreibung Descripción Descriçao Descripción Omschrijving Περιγραφή Nimitys Beskrivelse Beskrivelse Beskrivning	Contents Sommaire Inhalt Indice Conteúdo Contenuto Inhoud Περιεχόμενα Sisältö Indhold Innhold Innehåll	Dimensions Dimensions Abmessungen Dimensiones Dimensões Dimensioni Afmetingen Διαστάσεις Mitat Dimensioner Dimensjoner Dimensioner
32	9234 0000 59	1	Rope		
33	9234 0000 45	1	Handle		
34	9232 0115 30	3	Screw		M6SF 6x20
[35]	9234 0002 01	1	Fan cover assy	35-36	
35	-	1	Fan cover	*)	
36	9232 0115 30	2	Screw		M6SF 6x20
[37]	9234 0000 81	1	Fan Assy	37, 63-66	
37	-	1	Fan	*)	
38	9234 0009 98	1	Rubber insert		
39	9232 0905 30	1	Rope guide		L=142
40	9232 0207 50	2	Nut		M6
[41]	9234 0001 20	1	Muffler Assy	41-49	
41	-	1	Muffler	*)	
42	9232 0122 00	2	Screw		M6SF 6x45
43	9234 0004 86	2	Spring		
44	9232 0124 00	2	Screw		M6S 6X12 8.8
45	9234 0004 13	1	Gasket		
46	9234 0004 02	1	Muffler insert		
47	9234 0002 67	1	Gasket		
48	9234 0006 74	1	Hinge		
49	9234 0004 10	1	Hinge pin		FRP Ø5x80
50	9234 0005 33	1	Screw		M5x25
51	9234 0002 43	1	Heat Shield		
[52]	9234 0005 81	1	Leaf Spring Assy	52, 53	
52	9234 0001 45	1	Leaf Spring, right	61	
53	9234 0001 44	1	Leaf Spring, left	*)	
54	9234 0003 32	1	Pressure plate, top left		
55	9234 0002 99	2	Screw		M6SF 6x16 FZB
56	9234 0003 36	3	Pressure Plate		
[57]	9234 0001 43	1	End Stop Bracket Assy	40, 57, 58	
57	-	1	End Stop Bracket	*)	
58	9234 0003 35	1	Plastic Bush		
59	9232 0503 50	1	Lock ring		
61	-	2	Dampening Cushion	*)	
62	0301 2321 00	2	Washer		
63	9234 0000 84	1	Hub		
64	0384 3310 00	1	Cup Spring		
65	9234 0000 85	1	Washer		
66	9232 0209 00	1	Nut		
67	-	1	Decal, EPA	*)	

B

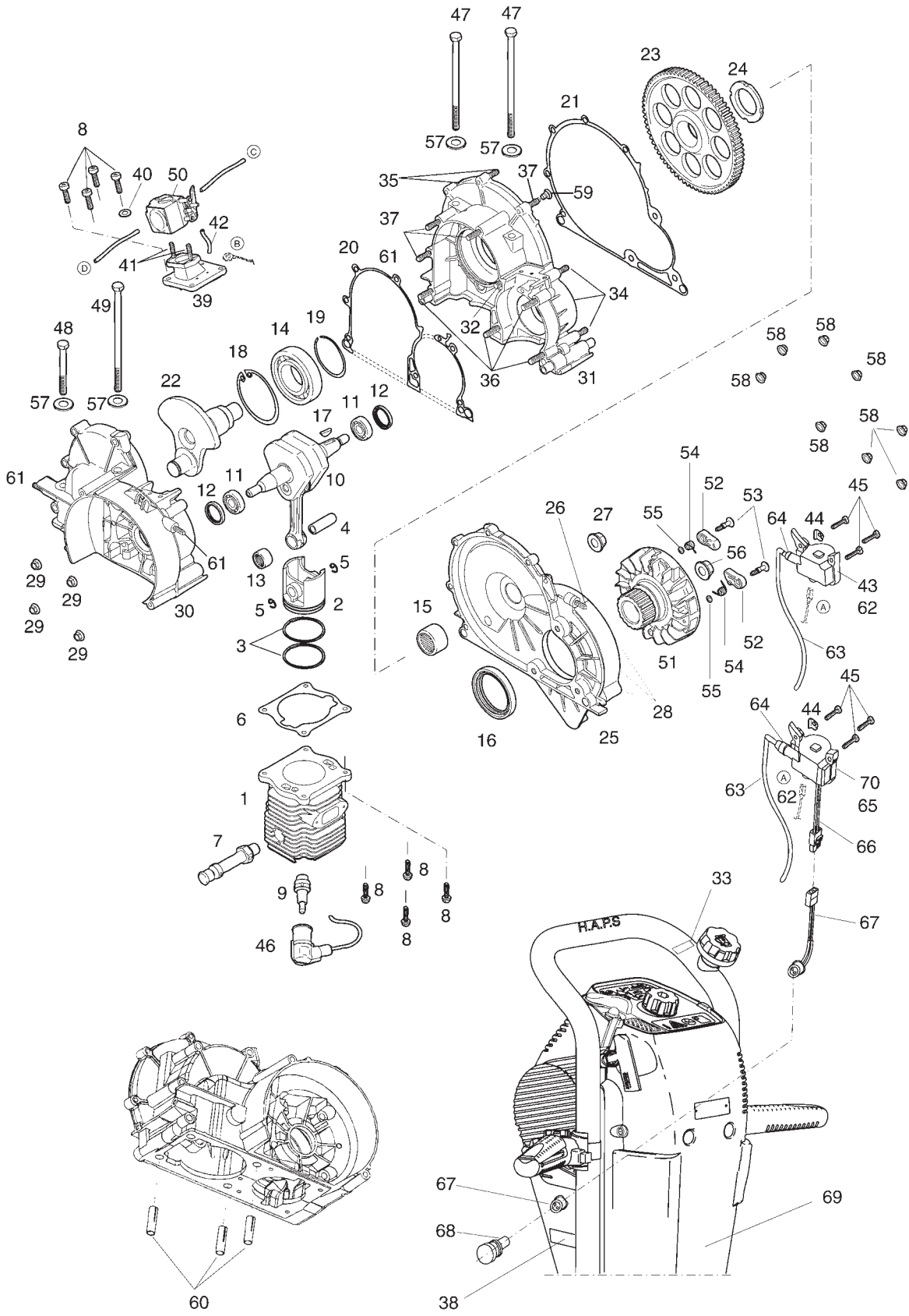

Fig. No. No. de fig. Abb. Nr. Núm de fig. Fig. No No rif. Fig. Nr Αριθ Σχ. Kuva nr. Fig. nr. Fig. nr.	Ordering No Référéce Bestellnummer Núm. pedido Encomenda No No Cat. Bestel nr. Αριθ. Παραγγελίας Tilaus nro. Bestillingsnummer Bestillingsnummer	Quantity Quantité Anzahl Cantidad Qvantidade Quantità Aantal Ποσότητα Lukumäärä Antal Antall	Description Description Beschreibung Descripción Descriçao Descrição Omschrijving Περιγραφή Nimitys Beskrivelse Beskrivelse	Contents Sommaire Inhalt Indice Conteúdo Contenuto Inhoud Περιεχόμενα Sisältö Inndhold Innhold	Dimensions Dimensions Abmessungen Dimensiones Dimensões Dimensioni Afmetingen Διαστάσεις Mitat Dimensioner Dimensjoner
[1]	9234 0001 06	1	Motor Cylinder Assy	1-8, 13	
1	-	1	Cylinder	*)	
2	-	1	Piston	*)	
3	9234 0000 07	2	Piston Ring		
4	9234 0000 08	1	Gudgeon Pin		
5	9234 0000 09	2	Lock Ring		
6	9234 0001 26	1	Gasket		
7	9234 0003 40	1	De-Compression Valve		
8	9232 0118 80	4	Screw		
9	9234 0004 48	1	Spark Plug Assy		Champion RCJ8
10	9234 0000 38	1	Motor Crankshaft		
[11]	9234 0003 18	1	Bearing / Seal Kit	11-21	
11	-	2	Ball Bearing	*)	
12	9234 0006 06	2	Seal		
13	-	1	Needle Bearing	*)	
14	-	1	Ball Bearing	*)	
15	9234 0003 96	1	Needle Bearing		
16	9234 0000 74	1	Seal		
17	9232 2228 40	1	Woodruff Key		
18	9234 0000 72	1	Lock Ring		
19	9234 0000 75	1	Lock Ring		
20	9234 0004 14	1	Gasket, crankcase		
21	9234 0004 15	1	Gasket, transmission cover		
22	9234 0005 37	1	Transmission Axle		
23	9234 0002 79	1	Transmission Cog Wheel		
24	9234 0000 76	1	Nut		KML-6 left
[25]	9234 0003 20	1	Transmission Cover Assy	15, 16, 25-28, 58	
25	-	1	Transmission Cover	*)	
26	9234 0004 23	1	Stud		M6x18, L=28
27	9234 0005 27	1	Oil Level plug		R1/4"
28	-	3	Thread insert	*)	
29	9232 0207 50	16	Nut		M6
[30]	9234 0002 82	1	Crankcase Assy	30, 31	
30	-	1	Crankcase, fan side	*)	
31	-	1	Crankcase, transmission side	*)	
32	9234 0001 58	1	Stud		M6x70, L=85
33	9234 0009 09	1	Decal		Oil mix 2%
34	9234 0000 71	3	Stud		M6x20, L=32
35	9234 0001 57	3	Stud		M6x25, L=40
36	9234 0000 69	4	Stud		M6x50, L=65
37	9234 0000 67	5	Stud		M6x30, L=45
38	-	1	Decal, EPA	*)	
[39]	9234 0006 22	1	Crankcase Valve Assy	8, 39-42,	

B

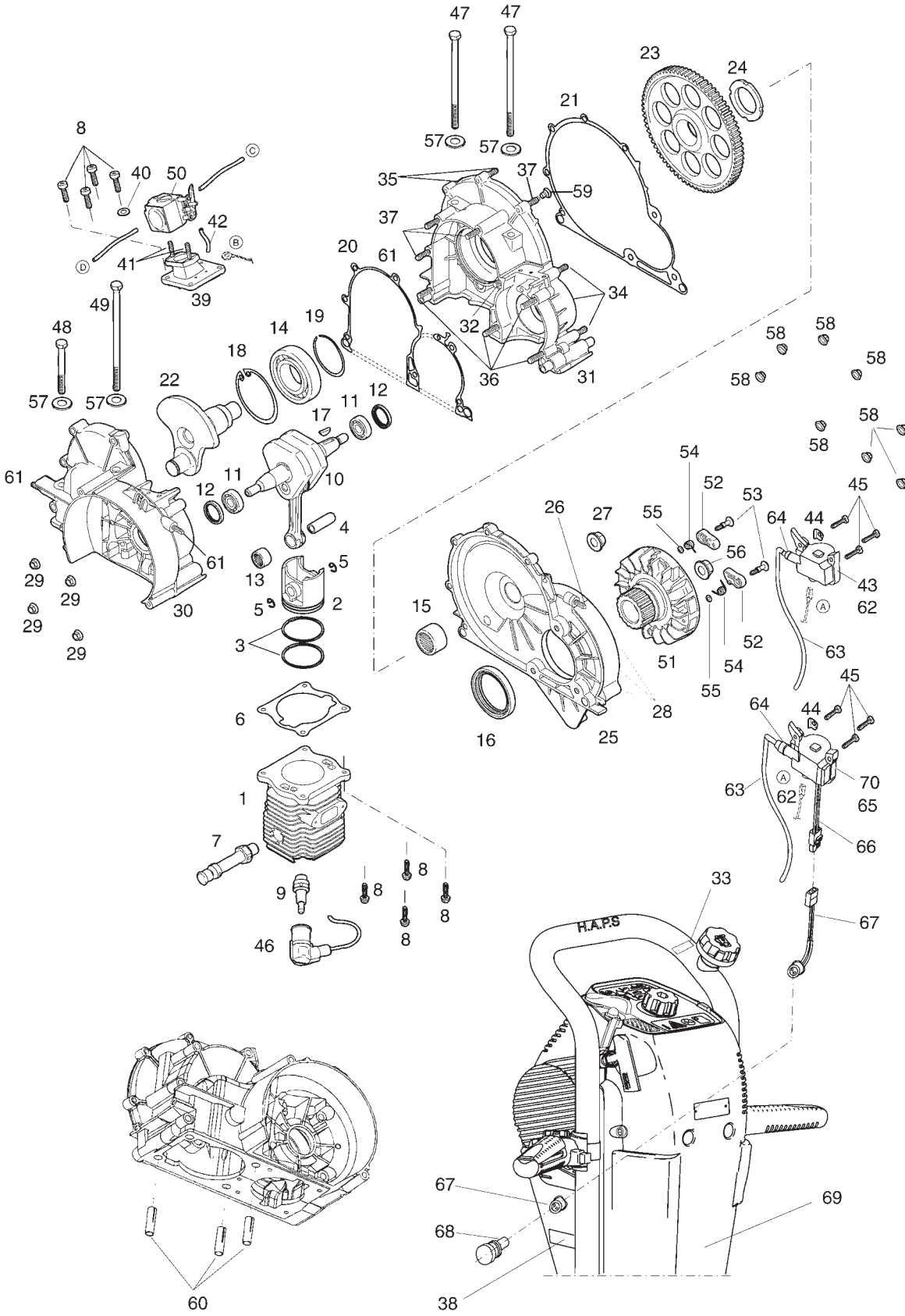

Fig. No. No. de fig. Abb. Nr. Núm de fig. Fig. No No rif. Fig. Nr Αριθ Σχ. Kuva nr. Fig. nr. Fig. nr. Fig. nr.	Ordering No Référéce Bestellnummer Núm. pedido Encomenda No No Cat. Bestel nr. Αριθ. Παραγγελίας Tilaus nro. Bestillingsnummer Bestillingsnummer Best. nummer	Quantity Quantité Anzahl Cantidad Qvantidade Quantità Aantal Ποσότητα Lukumäärä Antal Antall Antal	Description Description Beschreibung Descripción Descriçao Descrição Omschrijving Περιγραφή Nimitys Beskrivelse Beskrivelse Beskrivning	Contents Sommaire Inhalt Índice Conteúdo Contenuto Inhoud Περιεχόμενα Sisältö Inndhold Innhold Innehåll	Dimensions Dimensions Abmessungen Dimensiones Dimensões Dimensioni Afmetingen Διαστάσεις Mitat Dimensioner Dimensjoner Dimensioner
39	-	1	Crankcase Valve	*)	
40	0301 2318 00	1	Washer		BRB 5.3X10X1
41	9234 0001 80	2	Stud		
42	9234 0003 24	1	Pipe		L=36mm
[43]	9234 0002 81	1	Electronic Unit Assy	44, 45, 46 [62]	
44	9234 0002 05	1	Protective washer		
45	9232 0120 00	3	Screw		
[46]	9234 0006 01	1	Spark Plug Cable Assy	46, 63, 64	
46	-	1	Spark Plug Cap	*)	
47	0147 1347 03	2	Screw		M6S 8x160 FZB 8.8
48	0147 1335 03	1	Screw		M6S 8x75 FZB 8.8
49	0147 1345 03	1	Screw		M6S 8x140 FZB 8.8
50	9234 0006 82	1	Carburettor		
[51]	9234 0003 04	1	Flywheel Assy	17, 51-56	
51	-	1	Flywheel	*)	
52	9234 0000 32	2	Carrier		
53	9234 0001 54	2	Screw		
54	9234 0001 55	2	Carrier Spring		
55	9234 0002 00	2	Support Washer		
56	9232 0209 00	1	Locking Nut		M6MF M10 8.8
57	0300 0274 74	4	Washer		BRB 8.4X16X1.5
58	9232 0207 50	8	Nut		M6
59	9232 0905 20	1	Bushing		
60	9234 0005 75	3	Plastic Bushing		
61	9234 0004 23	3	Stud		
[62]	-	1	Electronic Unit Assy	*) 62, 63, 64	
62	-	1	Electronic Unit	*)	
63	-	1	Ignition Cable	*)	
64	-	1	Grommet	*)	
-	9234 0009 12	1	Repair kit, carburettor		
[65]	-	1	Electronic Unit Assy	*) 63, 64, 65, 66	For Cobra TT / AWD
65	-	1	Electronic Unit	*)	
66	-	1	Contact Housing	*)	
[67]	9234 0006 68	1	Contact Housing Assy		For Cobra TT / AWD
[68]	9234 0006 65	1	Adapter Assy		For Cobra TT / AWD
69	9234 0006 52	1	Front Cover	[A6]	For Cobra TT / AWD
70	9234 0006 60	1	Electronic Unit Assy	44, 45, 46 [65]	For Cobra TT / AWD

Atlas Copco two stroke oil/ Huile 2 temps Atlas Copco/ Atlas Copco Zweitaktöl / Aceite Atlas Copco para motores de dos tiempos/ Óleo Atlas Copco de dois tempos/ Atlas Copco per motori a due temp/ Atlas Copco Tweetak-olie/ Λάδι δίχρονου κινητήρα της Atlas Copco/ Atlas Copco kaksitahtiöljy/ Atlas Copco two-stroke oil/ Atlas Copco totaktsolja/ Atlas Copco tvåtaktsolja

9238 2743 50

1 L

Fully synthetic and biodegradable

[]

*)

See page
Voir page

G

C

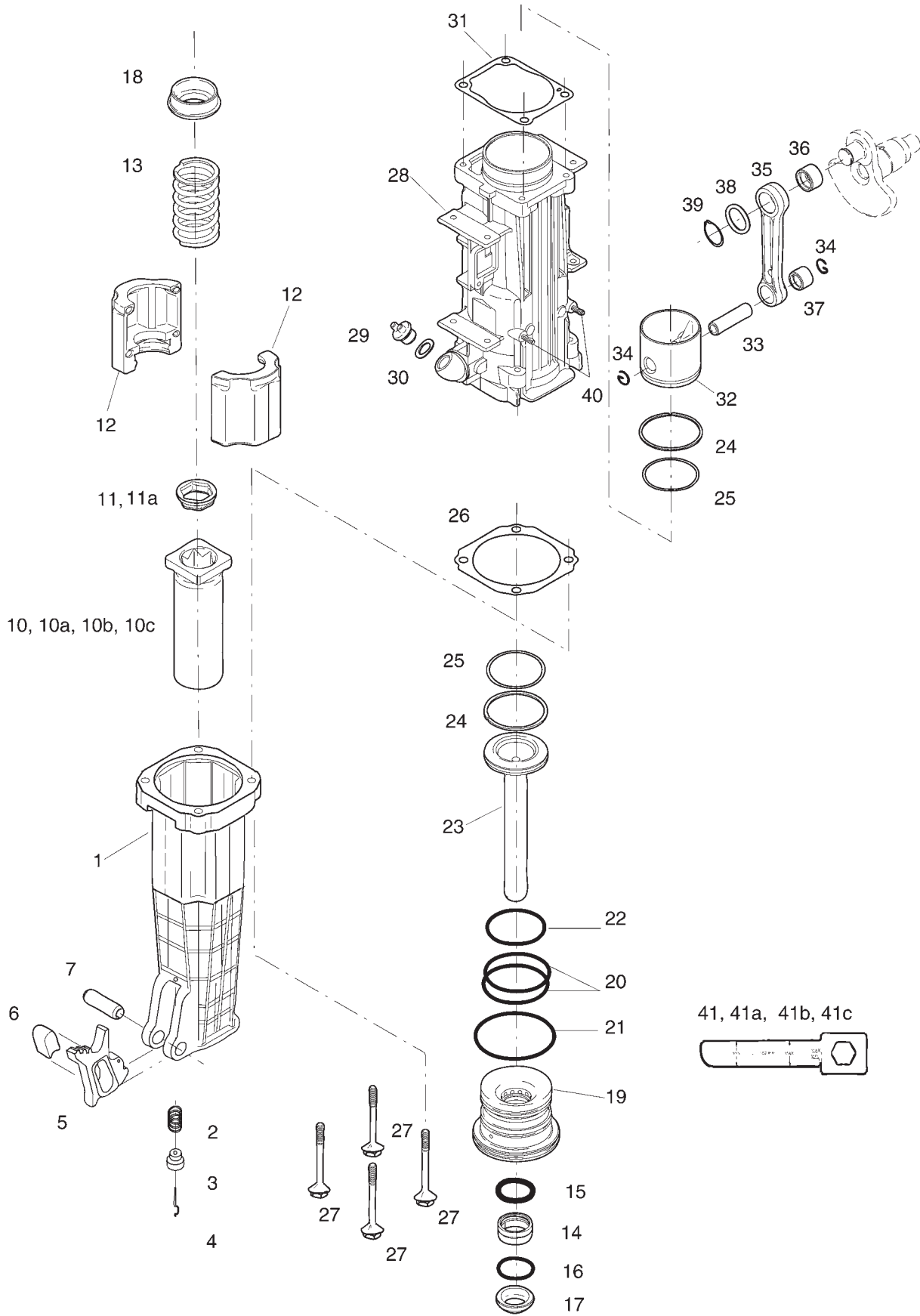

Fig. No. No. de fig. Abb. Nr. Núm de fig. Fig. No No rif. Fig. Nr Αριθ Σχ. Kuva nr. Fig. nr. Fig. nr. Fig. nr.	Ordering No Référéce Bestellnummer Núm. pedido Encomenda No No Cat. Bestel nr. Αριθ. Παραγγελίας Tilaus nro. Bestillingsnummer Bestillingsnummer Best. nummer	Quantity Quantité Anzahl Cantidad Qvantidade Quantitá Aantal Ποσότητα Lukumäärä Antal Antall Antal	Description Description Beschreibung Descripción Descriçao Descripción Omschrijving Περιγραφή Nimitys Beskrivelse Beskrivelse Beskrivning	Contents Sommaire Inhalt Índice Conteúdo Contenuto Inhoud Περιεχόμενα Sisältö Indhold Innhold Innehåll	Dimensions Dimensions Abmessungen Dimensiones Dimensões Dimensioni Afmetingen Διαστάσεις Mitat Dimensioner Dimensjoner Dimensioner
[1]	9234 0005 55	1	Breaker Housing Assy	1 [5]	
1	-	1	Breaker Housing	*)	
2	-	1	Spring	*)	
3	-	1	Guide	*)	
4	-	1	Guide Pin	*)	
[5]	9234 0006 37	1	Tool Latch Assy	2-7	
5		1	Tool Latch	*)	
6	-	1	Tool Latch Insert	*)	
7	-	1	Spring Pin	*)	
8					
9					
[10]	9234 0005 44	1	Tool Chuck Assy	10, 11	32X160,1 1/4"X6 1/4"
10	-	1	Tool Chuck	*)	32X160,1 1/4"X6 1/4"
[10a]	9234 0005 48	1	Tool Chuck Assy	10a, 11	32X152,1 1/4"X6"
10a	-	1	Tool Chuck	*)	32X152,1 1/4"X6"
[10b]	9234 0005 49	1	Tool Chuck Assy	10b, 11a	28X160,1 1/8"X6 1/4"
10b	-	1	Tool Chuck	*)	28X160,1 1/8"X6 1/4"
[10c]	9234 0005 50	1	Tool Chuck Assy	10c, 11a	28X152,1 1/8"X6"
10c	-	1	Tool Chuck	*)	28X152,1 1/8"X6"
11	9234 0005 17	1	Seal		1 1/4"
11a	9234 0005 24	1	Seal		1 1/8"
12	9234 0005 35	2	Feed stop		
13	9234 0001 79	1	Recoil Spring		
[14]	9234 0005 54	1	Scraper Ring Assy	14-18	
14	-	1	Speed seal	*)	
15	-	1	O-ring	*)	
16	-	1	Lock Ring	*)	
17	-	1	Scraper Ring	*)	
18	9234 0005 36	1	Support Ring		
[19]	9234 0005 47	1	Piston Guide Assy	[14] 19-22	
19	-	1	Piston Guide	*)	
20	9234 0002 28	2	O-ring		
21	9234 0002 29	1	O-ring		
22	9234 0002 30	1	O-ring		
[23]	9234 0003 00	1	Hammer Piston Assy	23 [24]	
23	-	1	Hammer Piston	*)	
[24]	9234 0002 71	1	Piston Ring Assy	24-25	
24	-	2	Piston Ring	*)	
25	-	2	O-ring	*)	
26	9234 0001 28	1	Gasket		
27	9234 0005 80	4	Screw		

C

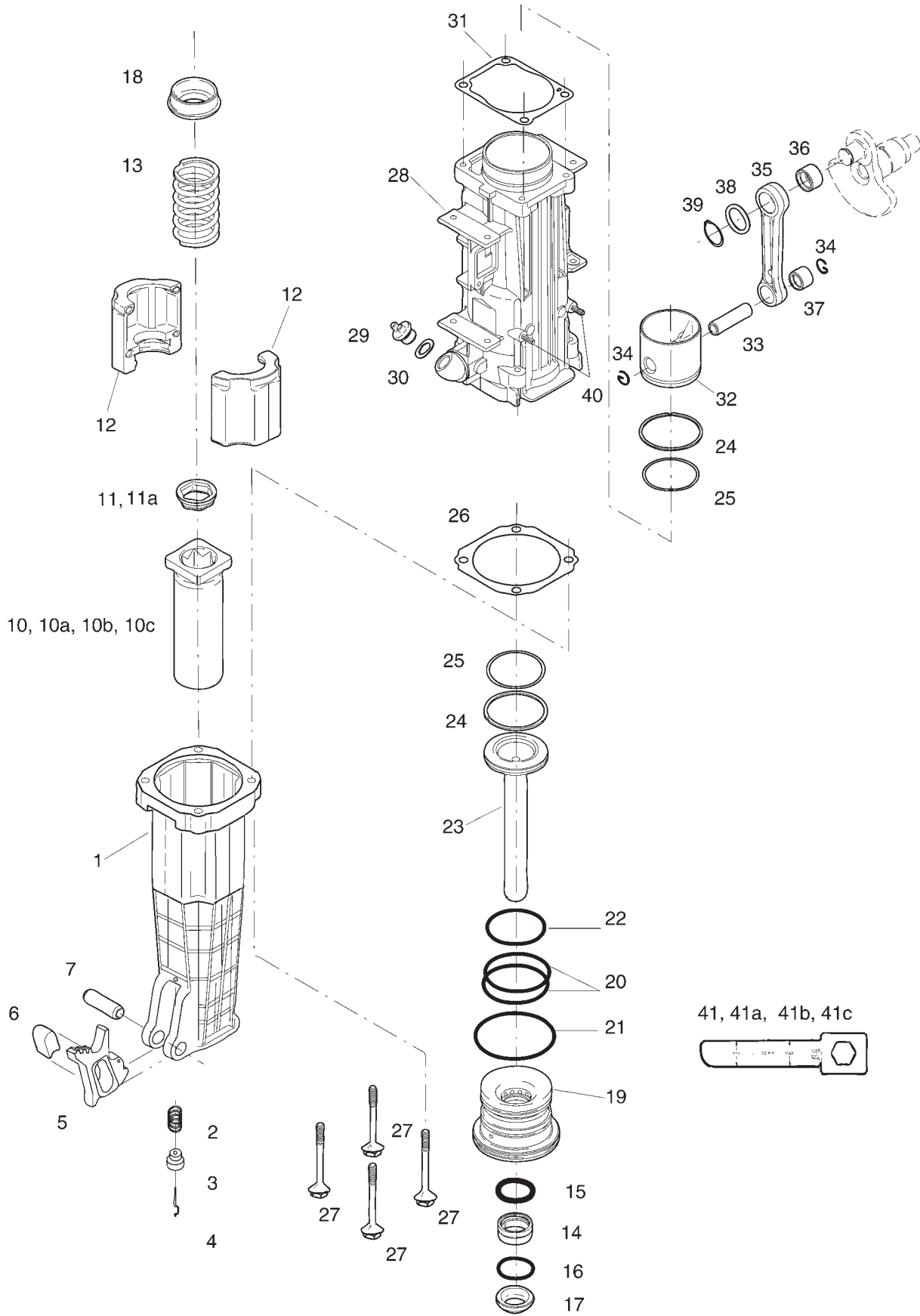

Fig. No. No. de fig. Abb. Nr. Núm de fig. Fig. No No rif. Fig. Nr Αριθ Σχ. Kuva nr. Fig. nr. Fig. nr. Fig. nr.	Ordering No Référéce Bestellnummer Núm. pedido Encomenda No No Cat. Bestel nr. Αριθ. Παραγγελίας Tilaus nro. Bestillingsnummer Bestillingsnummer Best. nummer	Quantity Quantité Anzahl Cantidad Qvantidade Quantità Aantal Ποσότητα Lukumäärä Antal Antall Antal	Description Description Beschreibung Descripción Descriçao Descripción Omschrijving Περιγραφή Nimitys Beskrivelse Beskrivelse Beskrivning	Contents Sommaire Inhalt Indice Conteúdo Contenuto Inhoud Περιεχόμενα Sisältö Indhold Innhold Innehåll	Dimensions Dimensions Abmessungen Dimensiones Dimensões Dimensioni Afmetingen Διαστάσεις Mitat Dimensioner Dimensjoner Dimensioner
[28]	9234 0004 08	1	Hammer Cylinder Assy	26, 28 [29] 31, 40	
28	-	1	Hammer Cylinder	*)	
[29]	9232 0123 51	1	Oil Plug Assy	29-30	
29	-	1	Oil Plug	*)	
30	9232 0310 90	1	O-ring		
31	9234 0001 27	1	Gasket		
[32]	9234 0003 01	1	Drive Piston Assy	[24] 32-34	
32	-	1	Drive Piston	*)	
33	9234 0002 45	1	Gudgeon Pin		
34	9232 0505 60	2	Circlip		
[35]	9234 0006 18	1	Connection Rod Assy	35-39	
35	-	1	Connection Rod	*)	
36	9234 0003 96	1	Needle Bearing		
37	4090 0369 00	1	Needle Bearing		
38	9234 0004 12	1	Shim		
39	9234 0002 84	1	Lock Ring		
40	9234 0004 23	2	Stud	M6x18 L=28 mm	
41	9238 2738 80	1	Template	32x160, 1¼"x6¼"	
41a	9238 2738 70	1	Template	32x152, 1¼"x6"	
41b	9238 2743 00	1	Template	28x152, 1⅛"x6"	
41c	9238 2743 10	1	Template	28x160, 1⅛"x6¼"	

D

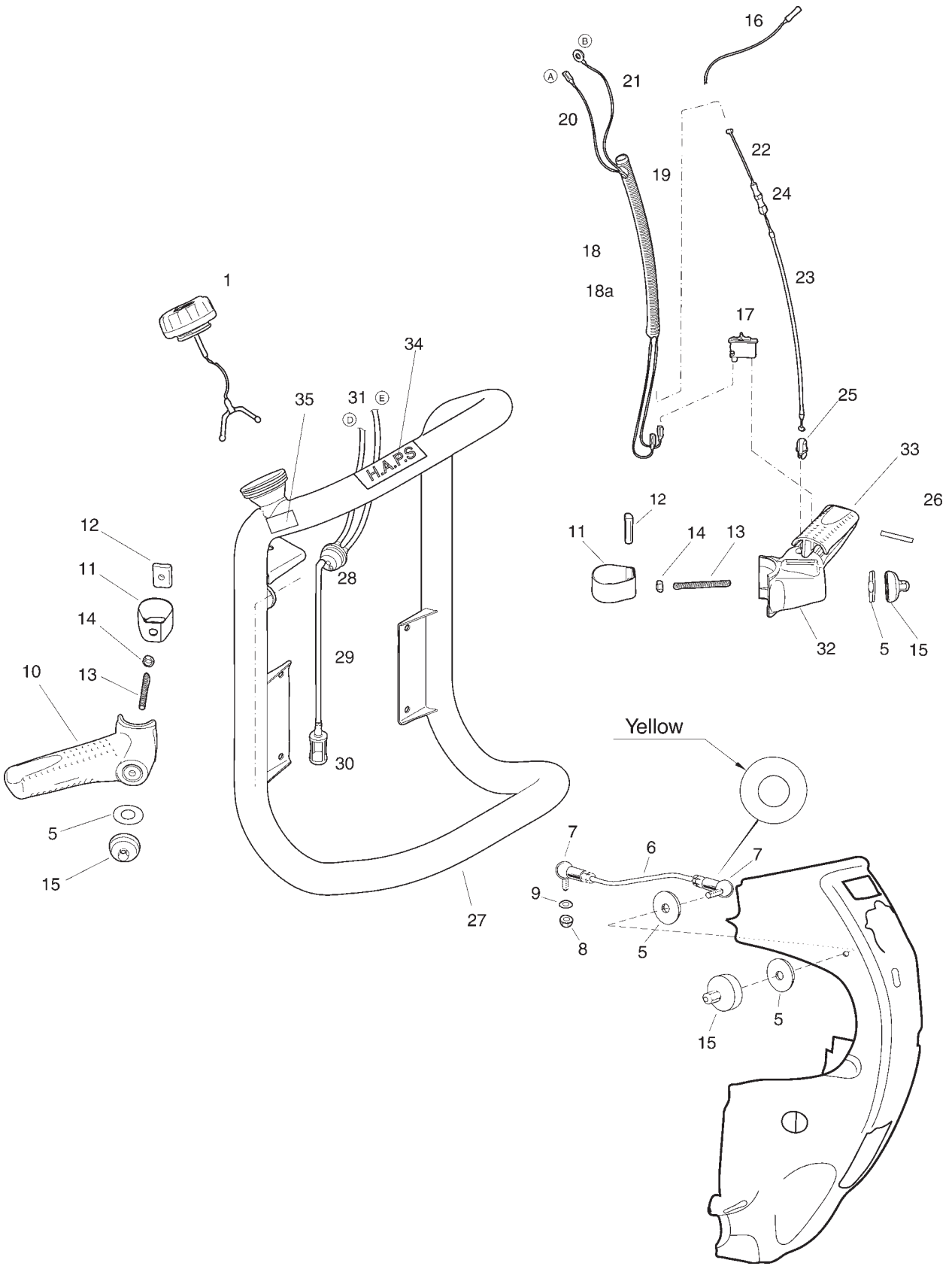

Fig. No. No. de fig. Abb. Nr. Núm de fig. Fig. No No rif. Fig. Nr Αριθ Σχ. Kuva nr. Fig. nr. Fig. nr.	Ordering No Référéce Bestellnummer Núm. pedido Encomenda No No Cat. Bestel nr. Αριθ. Παραγγελίας Tilaus nro. Bestillingsnummer Bestillingsnummer	Quantity Quantité Anzahl Cantidad Qvantidade Quantità Aantal Ποσότητα Lukumäärä Antal	Description Description Beschreibung Descripción Descriçao Descripción Omschrijving Περιγραφή Nimitys Beskrivelse Beskrivelse	Contents Sommaire Inhalt Indice Conteúdo Contenuto Inhoud Περιεχόμενα Sisältö Indhold Innhold	Dimensions Dimensions Abmessungen Dimensiones Dimensões Dimensioni Afmetingen Διαστάσεις Mitat Dimensioner Dimensjoner
[1]	9234 0006 38	1	Tank Cap Assy		
2					
3					
4					
5	9234 0005 84	1	Washer		
[6]	9234 0007 50	1	Stabilization Arm Assy	5-9, 15	
6		1	Stabilization Arm	*)	
7		2	Toggle Joint	*)	
8	9232 0207 50	1	Nut		M6,DIN 6927
9	0301 2321 00	1	Washer		6.4x12 T=1.5
[10]	9234 0005 68	1	Handle Assy, right	5, 10	
10	-	1	Handle, right	*)	
[11]	9234 0002 78	1	Handle Strap Assy	11-14	
11	-	1	Strap	*)	
12	-	1	Nut	*)	
13	-	1	Stud	*)	
14	9234 0005 10	1	Nut		M6MF M6
15	9234 0002 18	3	Handle Locking nut		
16	9234 0004 69	1	Plastic tie band		
17	9234 0001 11	1	Stop Switch		
[18]	9234 0005 32	1	Protection Pipe Assy	[18a] [22] 25	
[18a]	9234 0002 55	1	Protection Pipe Assy	19-21	
19	-	1	Protection Pipe	*)	
20	-	1	Cable, induction coil	*)	L=690
21	-	1	Cable, earth connection	*)	L=395
[22]	9234 0002 12	1	Throttle Cable Assy	22-24	
22	-	1	Wire	*)	
23	-	1	Outer Cable	*)	
24	-	1	Adjustment Screw with Nut	*)	
25	9234 0004 90	1	Nipple		
26	9234 0005 65	1	Cylindrical Pin		CP 5X32
[27]	9234 0006 47	1	Handle frame/Fuel Tank Assy	[1] 27 [28] 34, 35	
27	-	1	Handle frame	*)	
[28]	9234 0004 84	1	Tank Grommet Assy	28-31	
28	-	1	Tank Grommet	*)	
29	9234 0004 85	1	Pipe, fuel filter		L=625
30	9232 2306 00	1	Filter		
31	9234 0002 97	1	Pipe, tank connection		L=340

D

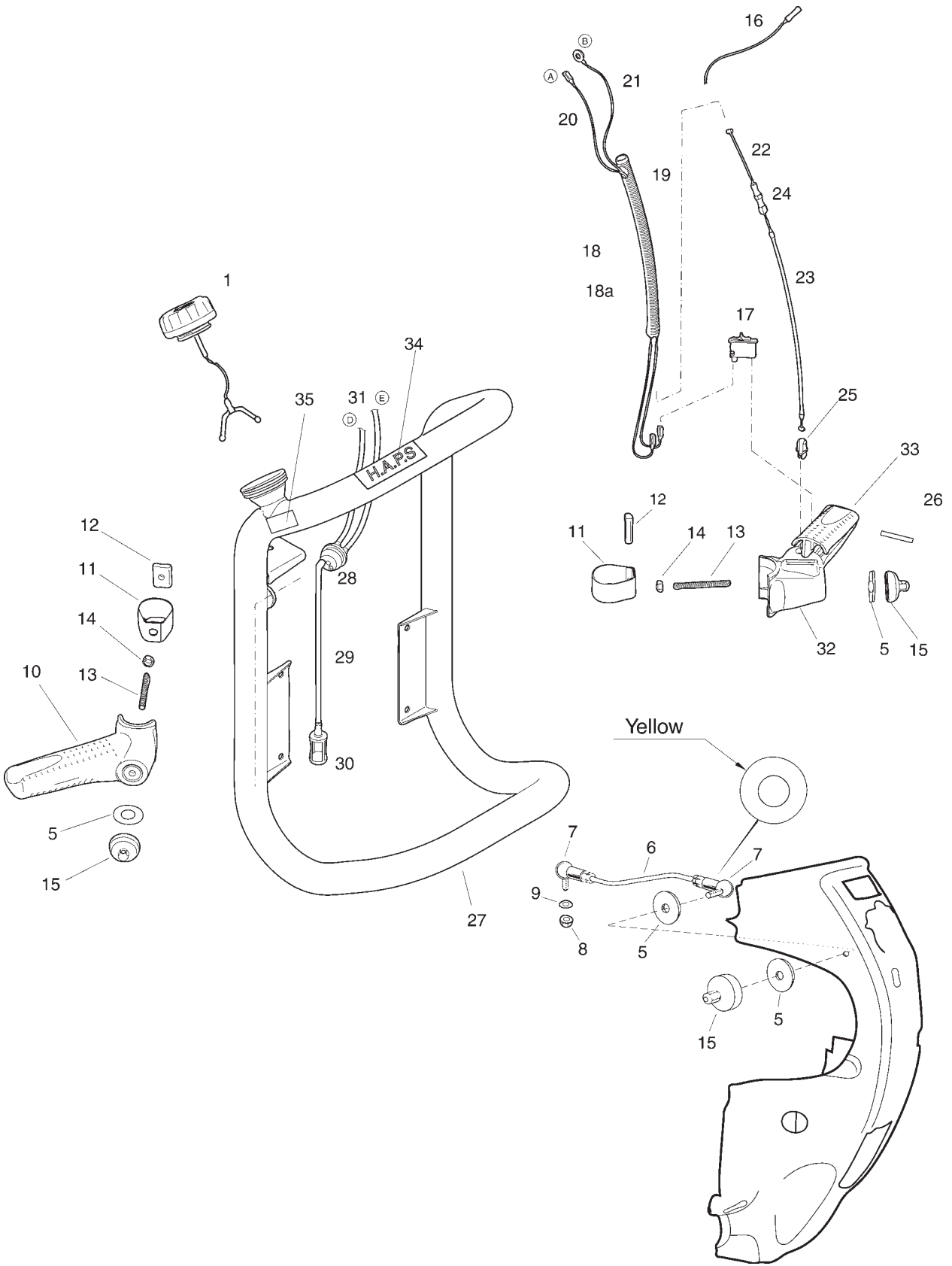

Fig. No. No. de fig. Abb. Nr. Núm de fig. Fig. No No rif. Fig. Nr Αριθ Σχ. Kuva nr. Fig. nr. Fig. nr.	Ordering No Réfarence Bestellnummer Núm. pedido Encomenda No No Cat. Bestel nr. Αριθ. Παραγγελίας Tilaus nro. Bestillingsnummer Bestillingsnummer	Quantity Quantité Anzahl Cantidad Qvantidade Quantitá Aantal Ποσότητα Lukumäärä Antal Antall	Description Description Beschreibung Descripción Descriçao Descripción Omschrijving Περιγραφή Nimitys Beskrivelse Beskrivelse	Contents Sommaire Inhalt Indice Conteúdo Contenuto Inhoud Περιεχόμενα Sisältö Indhold Innhold	Dimensions Dimensions Abmessungen Dimensiones Dimensões Dimensioni Afmetingen Διαστάσεις Mitat Dimensioner Dimensjoner
[32]	9234 0005 69	1	Handle Assy, left	5, 17 [18a] [22] 25a, 26, 32, 33	
32	9234 0004 87	1	Handle Assy		
33	9234 0005 25	1	Throttle control		
34	9234 0006 05	1	H.A.P.S, decal		
35	9234 0009 09	1	Decal		Oil mix 2%

E

Fig. No. No. de fig. Abb. Nr. Núm de fig. Fig. No No rif. Fig. Nr Αριθ Σχ. Kuva nr. Fig. nr. Fig. nr.	Ordering No Référence Bestellnummer Núm. pedido Encomenda No No Cat. Bestel nr. Αριθ. Παραγγελίας Tilaus nro. Bestillingsnummer Bestillingsnummer	Quantity Quantité Anzahl Cantidad Quantidade Quantità Aantal Ποσότητα Lukumäärä Antal Antall	Description Description Beschreibung Descripción Descrição Descripción Omschrijving Περιγραφή Nimitys Beskrivelse Beskrivelse	Contents Sommaire Inhalt Indice Conteúdo Contenuto Inhoud Περιεχόμενα Sisältö Indhold Innhold	Dimensions Dimensions Abmessungen Dimensiones Dimensões Dimensioni Afmetingen Διαστάσεις Mitat Dimensioner Dimensjoner
---	---	--	---	---	--

Service kits

-	9234 0006 87	-	One month service kit
B9	9234 0004 48	1	- Spark plug
A21	9234 0001 36	1	- Air filter

-	9234 0006 88	-	Three months service kit
-	9234 0006 87	1	- One month service kit
[C14]	9234 0005 54	1	- Scraper ring assembly
C26	9234 0001 28	1	- Gasket

-	9234 0006 89	-	Six months service kit
-	9234 0006 88	1	- Three months service kit
C20	9234 0002 28	2	- O-ring
C21	9234 0002 29	1	- O-ring
C22	9234 0002 30	1	- O-ring
D30	9232 2306 00	1	- Filter
[C24]	9234 0002 71	2	- Piston ring assembly
C31	9234 0001 27	1	- Gasket
A25	9234 0001 37	1	- Gaske
A58	9234 0003 35	2	- Plastic bushing
B60	9234 0005 75	3	- Plastic bushing
A45	9234 0004 13	1	- Gasket
A47	9234 0002 67	1	- Gasket

-	9234 0006 90	-	Twelve months service kit
-	9234 0006 89	1	- Six months service kit
[B11]	9234 0003 18	1	- Bearing and seal kit
B3	9234 0000 07	2	- Piston ring
B6	9234 0001 26	1	- Gasket

Fig. No. No. de fig. Abb. Nr. Núm de fig. Fig. No No rif. Fig. Nr Αριθ Σχ. Kuva nr. Fig. nr. Fig. nr.	Ordering No Référence Bestellnummer Núm. pedido Encomenda No No Cat. Bestel nr. Αριθ. Παραγγελίας Tilaus nro. Bestillingsnummer Bestillingsnummer	Quantity Quantité Anzahl Cantidad Quantidade Quantità Aantal Ποσότητα Lukumäärä Antal Antall	Description Description Beschreibung Descripción Descrição Descripción Omschrijving Περιγραφή Nimitys Beskrivelse Beskrivelse	Contents Sommaire Inhalt Indice Conteúdo Contenuto Inhoud Περιεχόμενα Sisältö Inndhold Innhold	Dimensions Dimensions Abmessungen Dimensiones Dimensões Dimensioni Afmetingen Διαστάσεις Mitat Dimensioner Dimensjoner
---	---	--	---	--	--

Seal kit

-	9234 0006 91	-	Complete seal kit. (Includes all seals for an overhaul)
A25	9234 0001 37	1	- Gasket
A45	9234 0004 13	1	- Gasket
A47	9234 0002 67	1	- Gasket
B6	9234 0001 26	1	- Gasket
B12	9234 0006 06	2	- Seal
B16	9234 0000 74	1	- Seal
B20	9234 0004 14	1	- Gasket, crankcase
B21	9234 0004 15	1	- Gasket, transmission
C11	9234 0005 17	1	- Seal (1-1/4")
C11a	9234 0005 24	1	- Seal (1-1/8")
[C14]	9234 0005 54	1	- Scraper ring assembly
C14	*)	1	- - Speed seal
C15	*)	1	- - O-ring
C16	*)	1	- - Lock ring
C17	*)	1	- - Scraper ring
C18	9234 0005 36	1	- - Support ring
C20	9234 0002 28	2	- O-ring
C21	9234 0002 29	1	- O-ring
C22	9234 0002 30	1	- O-ring
[C24]	9234 0002 71	1	- Piston ring assembly
C24	*)	2	- - Piston ring
C25	*)	2	- - O-ring
C26	9234 0001 28	1	- Gasket
C30	9232 0310 90	1	- O-ring
C31	9234 0001 27	1	- Gasket

Repair kit

B-	9234 0009 12	-	Repair kit, carburettor
-	*)		- Gasket
-	*)		- Gasket
-	*)		- Diaphragm
-	*)		- Diaphragm

G

	Table of signs	Clefs	Zeichenerklärungen	Leyendas
[]	Complete	Compl.	Kompl.	Compl.
*)	No spare part	Pas pièce de rechange	Kein Ersatzteil	No es pieza de recambio

	Tabela de avisos	Legenda	Verklaring	Πίνακας πινακίδων
[]	Completo	Completo	Kompleet	Πλήρης
*)	Não há peças sobressalentes	Non ricambio	Geen wissel st.	Όχι ανταλλακτικά

	Kilpitaulukko	Signaturforklaring	Tegnforklaring	Teckenförklaringar
[]	Täydellinen	Komplet	Komplett	Komplett
*)	Ei varaosa	Ikke reservdel	Ingen reservdeler	Ej reservdel

Part Number	Fig.	Part Number	Fig.	Part Number	Fig.	Part Number	Fig.
0147 1335 03	B48	9234 0001 11	D17	9234 0003 54	A5	234 0006 47	[D27]
0147 1345 03	B49	9234 0001 14	[A26]	9234 0003 96	B15,C36	9234 0006 52	B69
0147 1347 03	B47	9234 0001 15	[A27]	9234 0004 02	A46	9234 0006 60	[B70]
0300 0274 74	B57	9234 0001 20	[A41]	9234 0004 08	[C28]	9234 0006 65	[B68]
0301 2318 00	B40	9234 0001 24	[A16]	9234 0004 10	A49	9234 0006 68	[B67]
0301 2321 00	A62,D9	9234 0001 26	B6	9234 0004 12	C38	9234 0006 74	A48
0384 3310 00	A64	9234 0001 27	C31	9234 0004 13	A45	9234 0006 82	B50
4090 0369 00	C37	9234 0001 28	C26	9234 0004 14	B20	9234 0006 86	A26
9232 0115 30	A34,A36	9234 0001 36	A21	9234 0004 15	B21	9234 0006 87	E
9232 0118 80	B8	9234 0001 37	A25	9234 0004 23	B26,B61	9234 0006 88	E
9232 0120 00	B45	9234 0001 43	[A57]	9234 0004 23	C40	9234 0006 89	E
9232 0122 00	A42	9234 0001 44	A53	9234 0004 48	B9	9234 0006 90	E
9232 0123 51	[C29]	9234 0001 45	A52	9234 0004 69	D16	9234 0006 91	F
9232 0124 00	A44	9234 0001 54	B53	9234 0004 84	[D28]	9234 0007 50	[D6]
9232 0207 50	A2,A40	9234 0001 55	B54	9234 0004 85	D29	9234 0009 09	B33, D35
9232 0207 50	B29,B58	9234 0001 57	B35	9234 0004 86	A43	9234 0009 12	B -
9232 0207 50	D8	9234 0001 58	B32	9234 0004 87	D32	9234 0009 95	A10
9232 0208 80	A19	9234 0001 79	C13	9234 0004 90	D25	9234 0009 97	A11
9232 0209 00	A66,B56	9234 0001 80	B41	9234 0004 91	A28	9234 0009 98	A38
9232 0310 90	C30	9234 0002 00	B55	9234 0005 10	D14	9234 0010 08	[A12]
9232 0503 50	A59	9234 0002 01	[A35]	9234 0005 17	C11	9234 0010 09	[B15]
9232 0505 60	C34	9234 0002 05	B44	9234 0005 24	C11a	9234 0010 30	A24
9232 0905 20	B59	9234 0002 12	[D22]	9234 0005 25	D33	9238 2738 70	C41a
9232 0905 30	A39	9234 0002 18	D15	9234 0005 27	B27	9238 2738 80	C41
9232 2228 40	B17	9234 0002 28	C20	9234 0005 32	[D18]	9238 2743 00	C41b
9232 2237 91	[A3]	9234 0002 29	C21	9234 0005 33	A50	9238 2743 10	C41c
9232 2306 00	D30	9234 0002 30	C22	9234 0005 34	A38		
9234 0000 07	B3	9234 0002 43	A51	9234 0005 35	C12		
9234 0000 08	B4	9234 0002 45	C33	9234 0005 36	C18		
9234 0000 09	B5	9234 0002 55	[D18a]	9234 0005 37	B22		
9234 0000 19	A6	9234 0002 65	[A22]	9234 0005 44	[C10]		
9234 0000 20	A1	9234 0002 67	A47	9234 0005 47	[C19]		
9234 0000 26	A23	9234 0002 71	[C24]	9234 0005 48	[C10a]		
9234 0000 32	B52	9234 0002 78	[D11]	9234 0005 49	[C10b]		
9234 0000 38	B10	9234 0002 79	B23	9234 0005 54	[C14]		
9234 0000 40	A29	9234 0002 81	[B43]	9234 0005 50	[C10c]		
9234 0000 41	A30	9234 0002 82	[B30]	9234 0005 55	[C1]		
9234 0000 45	A33	9234 0002 84	C39	9234 0005 65	D26		
9234 0000 54	A31	9234 0002 97	A17,D31	9234 0005 68	[D10]		
9234 0000 56	A8	9234 0002 98	A18	9234 0005 69	[D32]		
9234 0000 59	A32	9234 0002 99	A55	9234 0005 75	B60		
9234 0000 63	A20	9234 0003 00	[C23]	9234 0005 80	C27		
9234 0000 67	B37	9234 0003 01	[C32]	9234 0005 81	[A52]		
9234 0000 69	B36	9234 0003 04	[B51]	9234 0005 84	D5		
9234 0000 71	B34	9234 0003 18	[B11]	9234 0006 01	[B46]		
9234 0000 72	B18	9234 0003 20	[B25]	9234 0006 05	D34		
9234 0000 74	B16	9234 0003 24	B42	9234 0006 06	B12		
9234 0000 75	B19	9234 0003 32	A54	9234 0006 18	[C35]		
9234 0000 76	B24	9234 0003 35	A58	9234 0006 19	[A9]		
9234 0000 81	[A37]	9234 0003 36	A56	9234 0006 22	[B39]		
9234 0000 84	A63	9234 0003 40	B7	9234 0006 31	[B65]		
9234 0000 85	A65	9234 0003 43	A14	9234 0006 37	[C5]		
9234 0001 06	B1	9234 0003 45	A7	9234 0006 38	[D1]		

Use only authorized parts. Any damage or malfunction caused by the use of unauthorized parts is not covered by Warranty or Product Liability.

N'utiliser que des pièces approuvées. Tout endommagement ou fonctionnement défectueux résultant de l'utilisation de pièces non approuvées n'est pas couvert par Garantie et responsabilité du produit.

Nur zugelassene Teile verwenden. Schäden oder Funktionsstörungen, die auf die Verwendung nicht zugelassener Teile zurückzuführen sind, fallen nicht unter die Garantie- oder Produkthaftungsbestimmungen.

Sólo se pueden usar piezas autorizadas. Cualquier daño o funcionamiento defectuoso causado por el uso de piezas no autorizadas no se cubre por la Garantía o la Responsabilidad del Producto.

Use apenas peças autorizadas. Qualquer avaria ou mau funcionamento motivado pelo uso de peças não é coberto por garantia ou responsabilidade de riscos causados pelo produto.

Usare solamente parti autorizzate. I danni o disturbi del funzionamento causati dall'uso di parti non autorizzate, non sono coperti dalla Garanzia né dall'Assicurazione del prodotto.

Gebruik uitsluitend geautoriseerde onderdelen. Schade of gebreken veroorzaakt door het gebruik van niet-geautoriseerde onderdelen vallen niet onder de garantie of de produkt-aansprakelijkheid.

Χρησιμοποιείτε μόνο εγκεκριμένα εξαρτήματα. Τυχόν καταστροφή ή βλάβη η οποία προκαλείται από τη χρήση μη εγκεκριμένων εξαρτημάτων δεν καλύπτεται από την Εγγύηση ή την Ευθύνη Προϊόντος.

Käytä vain hyväksytyjä varaosia. Takuu ja tuotevastuu eivät korvaa hyväksymättömien varaosien käytöstä aiheutuvia vaurioita tai toimintahäiriöitä.

Brug kun autoriserede dele. Enhver skade eller fejlfunktion, der skyldes brugen af ikke-autoriserede dele, er ikke dækket af garantien eller produktansvarforsikringen.

Bruk bare godkjente deler. Enhver skade eller funksjonsfeil som skyldes bruk av ikke godkjente deler dekkes ikke av garanti eller produktansvar.

Använd endast godkända reservdelar. Skada eller funktionsfel som beror på användning av ej godkända reservdelar täcks inte av garantiåtaganden eller produktansvar.

Any unauthorized use or copying of the contents or any part thereof is prohibited. This applies in particular to trademarks, model designations, part numbers and drawings.

Toute utilisation ou reproduction non autorisée du contenu, ou d'une partie du contenu, est illicite. Cela s'applique particulièrement aux marques déposées, aux désignations de modèles, aux numéros de pièces et aux plans.

Unbefugter Gebrauch oder das Kopieren des Inhalts, auch auszugsweise, ist verboten. Dies gilt besonders für Warenzeichen, Modellbezeichnungen, Teilnummern und Zeichnungen.

Está prohibido cualquier uso o copia no autorizada del contenido o de cualquier parte de éste. Esto se aplica en especial a marcas registradas, denominaciones de modelos, números de piezas y dibujos.

Qualquer utilização não autorizada ou cópia de qualquer peça é expressamente proibida. Isto aplica-se em particular às marcas registradas, denominação dos modelos, referência de peças e desenhos.

E' vitata qualsiasi forma d'uso o copiatura non autorizzata del contenuto, anche parziale, con particolare riguardo ai marchi di fabbrica, alle denominazioni dei modelli, ai numeri delle parti ed ai disegni.

Niet-geautoriseerd gebruik of kopiëren van de inhoud of een deel daarvan is niet toegestaan. Dat geldt in het bijzonder voor handelsmerken, model-benamingen, onderdeel nummers en tekeningen.

Τυχόν μη εξουσιοδοτημένη χρήση ή αντιγραφή των περιεχομένων οποιουδήποτε μέρους του παρόντος απαγορεύεται. Αυτό ισχύει ιδιαίτερα στα σήματα κατατεθέντα, τις ονομασίες μοντέλων, τους αριθμούς ανταλλακτικών και τα σχέδιαγράμματα.

Sisällön tai sen osan luvaton käyttö tai kopiointi on kielletty. Tämä koskee erityisesti tavaramerkkejä, mallien nimiä, osanumeroita ja piirustuksia.

Enhver ikke-autoriseret brug eller kopiering af indholdet eller nogen del deraf er forbudt. Dette gælder især varemærker, modelbetegnelser, reservedelsnumre og tegninger.

Enhver ikke godkjent bruk eller kopiering av innholdet eller noen del av det er forbudt. Dette gjelder i særlig grad varemerker, modellbetegnelser, delnummer og tegninger.

Ej i förväg godkänd användning eller kopiering av innehållet eller del av detta är förbjuden. Detta gäller speciellt varumärken, modellbeteckningar, reservdelsnummer och ritningar.