

BOMAG

FAYAT GROUP

Steel Wheel Roller

BW9ASW



- Rugged, high-strength frame
- Two-speed transmission
- Corrosion-free water spray system
- Wide drum coverage
- Dual, center facing seats
- Hydrostatic drive
- No daily lubrication
- Low static linear load



Technical Specifications

BW9ASW

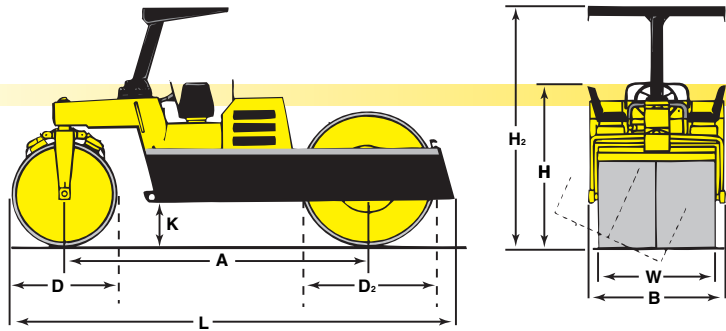

Dimensions
in inches (mm)
BW9ASW

A	B	D	D2	H	H2	K	L	W
132 (3353)	62.5 (1590)	40 (1016)	53 (1346)	74 (1880)	108 (2743)	16.5 (419)	183 (4648)	56 (1422)

Service

Service is an important element with all BOMAG compaction equipment. That's why there are BOMAG factory trained technicians everywhere—not far from your job. So when a wear part needs to be replaced on site, or when a service interval is due, BOMAG authorized service engineers and technicians are available no matter where the machine happens to be.

Standard equipment

- Cummins 4B3.3T Diesel Engine
- Pressurized Water Spray System
- Horn
- Front and Rear Drum Scrapers
- Cocoa mats
- Vandal Guards
- Falling-Object/Roll Over Protective Structure (FOPS/ROPS) and Seat belts

Optional equipment

- Headlights (Front and Rear)
- Turn Signals and 4-way Flashers
- Special Paint, 1 Color (Enamel Only)

Technical data

Weights

Metal weight.....	lbs	(kg)	14080	(6387)
Guide roll/Drive roll.....	lbs	(kg)	5970/8110	(2708/3679)
Weight with ballast.....	lbs	(kg)	19320	(8763)
Guide roll/Drive roll.....	lbs	(kg)	8540/10780	(3874/4890)
Max. static linear load (ave).....	lbs/in	(kg/cm)	173	(30.8)
Guide roll/Drive roll.....	lbs/in	(kg/cm)	153/193	(27.2/34.3)

Dimensions

Track radius, inner.....	in	(mm)	142	(3607)
Height with FOPS/ROPS.....	in	(mm)	108	(2743)

Driving Characteristics

Speed (1).....	mph	(km/h)	0-5.1	(0-8.2)
Speed (2).....	mph	(km/h)	0-10.2	(0-16.4)

Drive

Engine manufacturer.....	Cummins			
Type.....	4B3.3T			
Cooling.....	water			
Number of cylinders.....	4			
Performance SAE, brake.....	hp	(kW)	83	(62)
Speed.....	rpm	(min ⁻¹)	2400	(2400)
Fuel.....	diesel			
Electric equipment.....	V	12		
Drive system.....	hydrostatic			
Driven drum.....	R			

Brakes

Service brake.....	hydrostatic
Secondary/Parking brake.....	SAHR

Steering

Steering system.....	automotive-type			
Steering method.....	hydraulic			
Steering angle +/-.....	degrees	(grad)	45	(45)
Oscillating angle straight +/-.....	degrees	(grad)	25	(25)
Oscillating angle full turn +/-.....	degrees	(grad)	10	(10)

Water Spray System

Type of spray system.....	pressurized
---------------------------	-------------

Capacities

Fuel.....	gal	(l)	34	(128)
Water.....	gal	(l)	170	(645)
Hydraulic oil reservoir.....	gal	(l)	15	(57)
Coolant system.....	gal	(l)	4	(15)

Technical modifications reserved. Machines may be shown with options.