

BOMAG

Steel Wheel Rollers BW9AS, BW11AS



- Rugged, high-strength frame
- Two-speed transmission
- Corrosion-free water spray system
- Dual scrapers for each drum
- Low center of gravity for operating stability
- Ergonomically-engineered operator's compartment
- Hydrostatic drive
- No daily lubrication
- Standard FOPS/ROPS with seat belts
- Split/two piece steering drum(s)



BW9AS, BW11AS

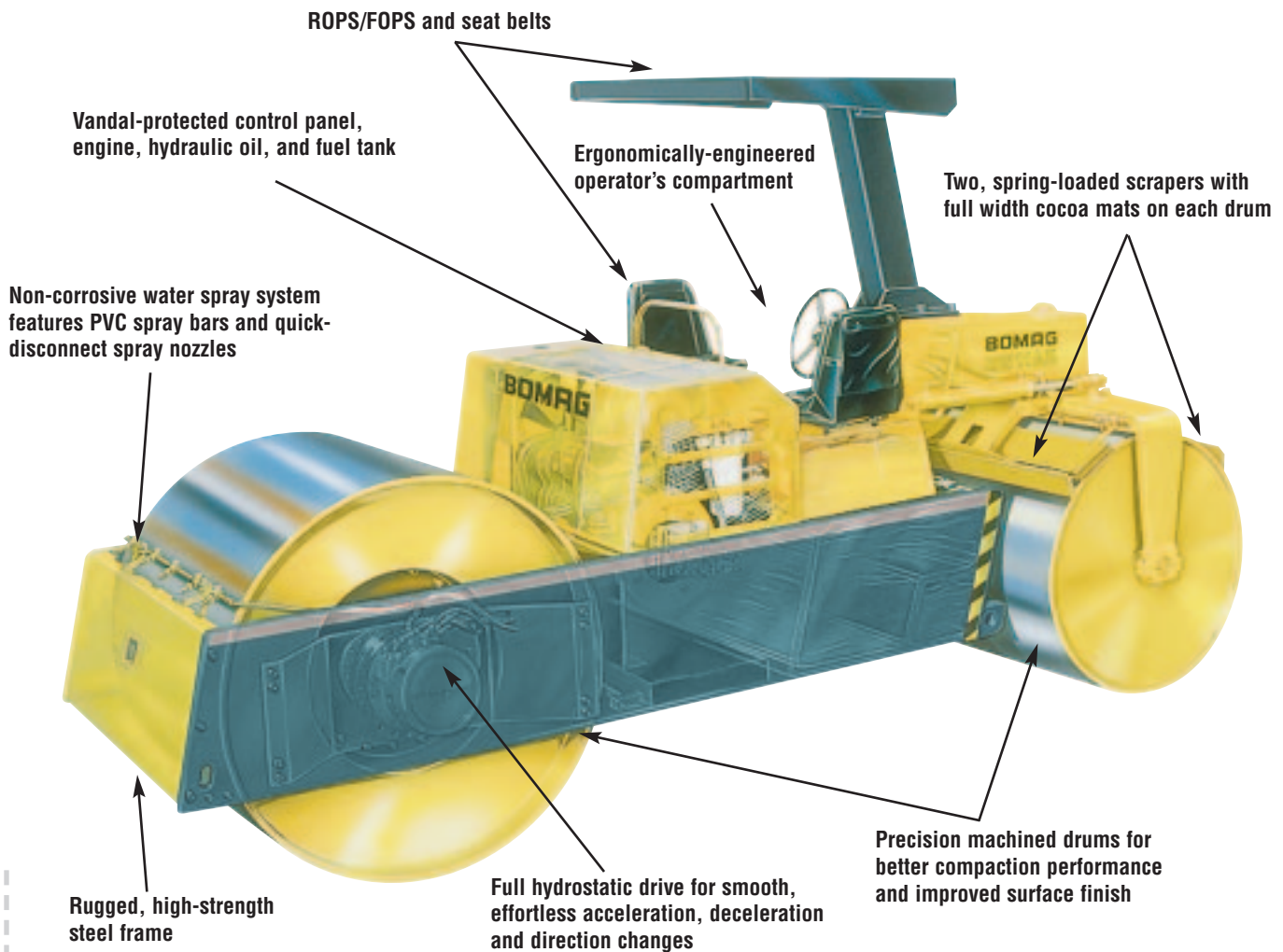

■ *Used for all phases of compaction, especially finish rolling...*

The ergonomically designed operator's compartment of the BW9AS and BW11AS delivers optimum comfort for the operator. Dual center-facing seats position the operator for visibility, control and comfort. Controls are placed for natural operator movements. The operator has full view of the exposed drums and the sides of the roller. Asphalt pick-up is sighted quickly, with exposed, easily viewed drums. With minimal frame overhang and no protruding components, working close to obstacles and curbs is easy.

■ Applications:

- Highway construction
- Commercial and residential paving
- Driveways
- Parking lots
- Asphalt resurfacing



Especially designed for all types of asphalt compaction



Controls are placed for natural operator movements

■ Handling is Easier & Safer:

- Simple ergonomic layout of controls makes operation easy.
- Brake(s) apply automatically when engine is shut down or with a loss of transmission hydraulic pressure.
- The water tank, fuel tank and engine are placed down inside the frame keeping a low center of gravity.
- The dual center-facing seats provide the operator excellent visibility of the drum and water spray system during travel in either direction.
- Falling-Object/Roll-Over Protective Structure (FOPS/ROPS) and seat belts are standard features.
- The transverse engine mounting keeps the operator comfortable by directing air, noise and exhaust 90° away.

These steel wheel rollers offer ease of operation and low maintenance

■ Achieve Maximum Productivity:

- Hydrostatic drive allows smooth, effortless acceleration, deceleration and directional changes.
- Two-speed transmission provides excellent gradeability in low range, top production in high range.
- Hydrostatic steering with automotive type steering wheel provides the operator with controlled maneuverability.
- Cummins 4B3.3T diesel engine provides ample reserve power for even the most demanding jobs.
- The precision machined drum(s) provide smooth, compacted surface results.
- Two-section steering drum minimizes scuffing on sharp turns.
- Dual scrapers and full width cocoa mats on each drum minimize asphalt pick-up.
- Hydrodynamic braking of hydrostatic drive system provides smooth, controlled, positive stops.

■ Less Service & Maintenance:

The purchase price is important, but so are the operating costs. Check these features:

- The frame overhang is minimal and all drive components are inside the frame.
- There are no “grease daily” fittings on either roller.
- High efficiency, 7-micron filter helps prolong hydraulic component life. Indicator light on console immediately alerts the operator when the filter requires service.
- Daily maintenance checkpoints and filters are easily reached.
- Pressure test port are grouped and labeled using standard capped fittings for quick hassle-free servicing.
- The non-corrosive water spray system features PVC spray bars and quick-disconnect spray nozzles.
- Center opening hood and swing-open side doors offering excellent engine area accessibility.

Featuring...

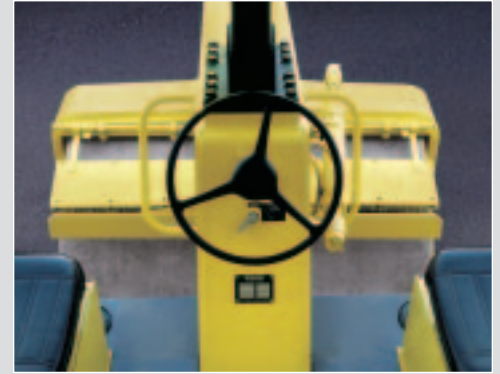

Dual operating seats provide an excellent view of the drum's edge



Each drum has a full width cocoa mat, two scrapper bars that clean in both travel directions, and five spray nozzles



The engine location is low in the frame for ease of service and operator visibility

With these features and many more, it's easy to see why these models maintain a high residual value while delivering lower lifetime operating costs.

Technical Specifications

BW9AS, BW11AS

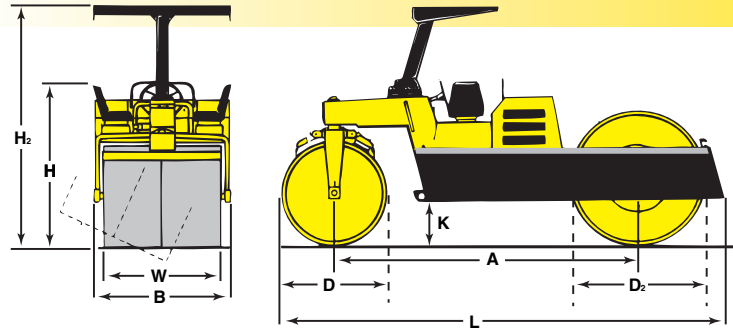

Dimensions in inches (mm)	A	B	D	D ₂	H	H ₂	K	L	W
BW9AS	132 (3353)	62.5 (1590)	40 (1016)	53 (1346)	74 (1880)	107 (2718)	16.5 (419)	183 (4648)	50 (1270)
BW11AS	140 (3555)	62.5 (1590)	48 (1220)	60 (1525)	77 (1955)	110 (2794)	20 (508)	198 (5030)	54 (1370)

Technical data

Weights

	BOMAG BW9AS	BOMAG BW11AS
Metal weight 5-8 ton	13986 (6343)	
Metal weight 8-10 ton	16226 (7360)	
Metal weight 8-12 ton		17320 (7855)
Metal weight 10-14 ton		21483 (9743)
Weight with ballast 5-8 ton	18876 (8572)	
Weight with ballast 8-10 ton	21116 (9578)	
Weight with ballast 8-12 ton		24250 (11013)
Weight with ballast 10-14 ton		28413 (12903)
Max. static linear load/drive drum 5-8 ton	216 (38.5)	
Max. static linear load/guide drum 5-8 ton	162 (28.9)	
Max. static linear load/drive drum 8-10 ton	246 (43.9)	
Max. static linear load/guide drum 8-10 ton	176 (31.5)	
Max. static linear load/drive drum 8-12 ton		251 (44.8)
Max. static linear load/guide drum 8-12 ton		198 (35.4)
Max. static linear load/drive drum 10-14 ton		304 (54.2)
Max. static linear load/guide drum 10-14 ton		223 (39.7)

Dimensions

Track radius, inner	142 (3607)	156 (3962)
Height with FOPS/ROPS	107 (2718)	110 (2794)

Driving Characteristics

Speed (1)	0-5.1 (0-8.2)	0-5.1 (0-8.2)
Speed (2)	0-10.2 (0-16.4)	0-10.2 (0-16.4)

Drive

Engine manufacturer	Cummins	Cummins
Type	4B3.3T	4B3.3T
Cooling	water	water
Number of cylinders	4	4
Performance SAE J1349	83 (62)	78 (58)
Speed	2400 (2400)	2100 (2100)
Fuel	diesel	diesel
Electric equipment	12	12
Drive system	hydrostatic	hydrostatic
Driven drum	R	R

Brakes

Service brake	hydrostatic	hydrostatic
Secondary/Parking brake	SAHR	SAHR

Steering

Steering system	automotive-type	automotive-type
Steering method	hydraulic	hydraulic
Steering angle +/-	45	45
Oscillating angle straight +/-	25	25
Oscillating angle full turn +/-	10	10

Water Spray System

Type of spray system	pressurized	pressurized
----------------------	-------------	-------------

Capacities

Fuel	34 (128)	34 (128)
Water	170 (645)	170 (645)
Hydraulic oil reservoir	15 (57)	15 (57)
Coolant system	4 (15)	4 (15)

Technical modifications reserved. Machines may be shown with options.

Standard equipment

- Cummins 4B3.3T Diesel Engine
- Pressurized Water Spray System with Flow Control
- Horn
- Front and Rear Drum Scrapers
- Full Drum Width Cocoa Mats
- Vandal Guards
- Dual Center-Facing Seats
- Full Hydrostatic Drive
- Hourmeter
- Indicator Gauges for:
 - Fuel Level
 - Transmission Oil Temperature
 - Engine Oil Pressure
 - Engine Coolant Temperature
 - Electrical System Voltage
- ROPS/FOPS and Seat Belts

Optional equipment

- Headlights (Front and Rear)
- Turn Signals and 4-way Flashers
- Special Paint, 1 Color (Enamel Only)

BOMAG
FAYAT GROUP

BOMAG Americas, Inc.

2000 Kentville Rd. • Kewanee, IL 61443
Tel: 309 853-3571 • Fax: 309 852-0350