

# KZ-26

## TRUCK-MOUNTED CONCRETE BOOM PUMP

Placing boom	B5Z 26/22
Pumping unit	PA 907 F8
Driven by	PTO
Chassis	2-3 axles



### DIMENSIONS

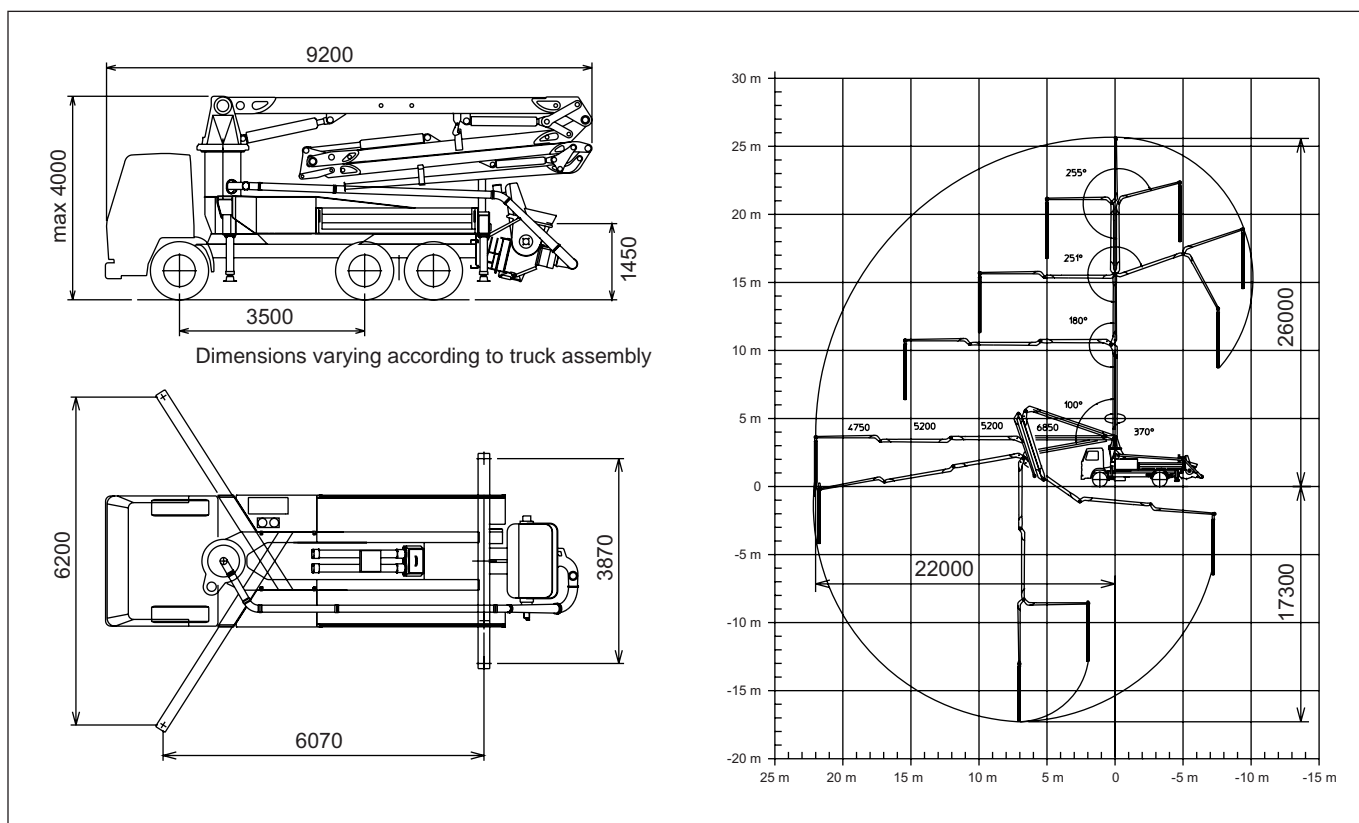

# KZ-26

## MAIN FEATURES

- Advantageous assembling on standard 2 or 3 axles chassis
- Self-supporting frame, torsion free, FEM designed
- Placing boom B5Z 26/22, 4 sections, pipeline diameter 125 mm, "Z" folding system
- Fully hydraulic outrigger controls on both sides of the truck
- Front outriggers "X" style for a quick set-up and easy pump placement in narrow areas
- Proportional boom control allowing the operator to control more placing boom sections simultaneously
- The "BFC" Best-Flex Cifa supporting system allowing just one man to change delivery pipeline easily, quickly and safely
- Concrete flow rate regulator
- Quiet pumping with high performances: smooth, continuous and easy movements
- Safety device on opening inspection hatch

## STANDARD EQUIPMENT

- 2 Proportional radio control with two boom movement speed, synthesiser for automatic frequency search, 8 position joy stick and concrete flow rate regulator. 20 mt cable
- Remote controlled vibrator on the concrete hopper grid
- Centralized lubrication system for pumping unit
- Additional manual lubrication system for pumping unit
- Hard plastic outrigger support plates with relative housing
- Rear light on hopper
- Level readers for stabilization control
- Accessories for cleaning and pipes washing

## OPTIONALS

- Double thickness concrete pipes, in high resistant steel
- High pressure water pump
- Air compressor for pipeline cleaning
- Centralized lubrication system for placing boom
- Air pipeline for placing boom
- Hopper covering
- Separated emergency engine kit for independent control of the hopper mixer, concrete pumping unit, boom and water pump

## TRUCK-MOUNTED CONCRETE BOOM PUMP

Placing boom	B5Z 26/22
Pumping unit	PA 907 F8
Driven by	PTO
Chassis	2-3 axles

## Pumping unit technical data

MODEL	PA 907 F8	
Max. theoretical output	<i>m³/h</i>	87
Max. pressure on concrete	<i>bar</i>	73
Max. numbers of cycles per min.	<i>nr.</i>	31
Conc. cylinders (diam. x stroke)	<i>mm</i>	200x1500
Concrete hopper capacity	<i>l</i>	550

## Placing boom technical data

MODEL	B5Z 26/22	
Pipeline diameter	<i>mm</i>	125
Max. vertical reach	<i>m</i>	26
Max. horizontal distance	<i>m</i>	22
Min. unfolding height	<i>m</i>	5,90
Section numbers	<i>n°</i>	4
1st section opening angle		-10°/90°
2nd section opening angle		180°
3rd section opening angle		251°
4th section opening angle		255°
Rotating angle		370°
End hose length	<i>m</i>	4

Technical data and characteristics subject to modifications without notice